

Werkzeugkatalog

tool catalogue

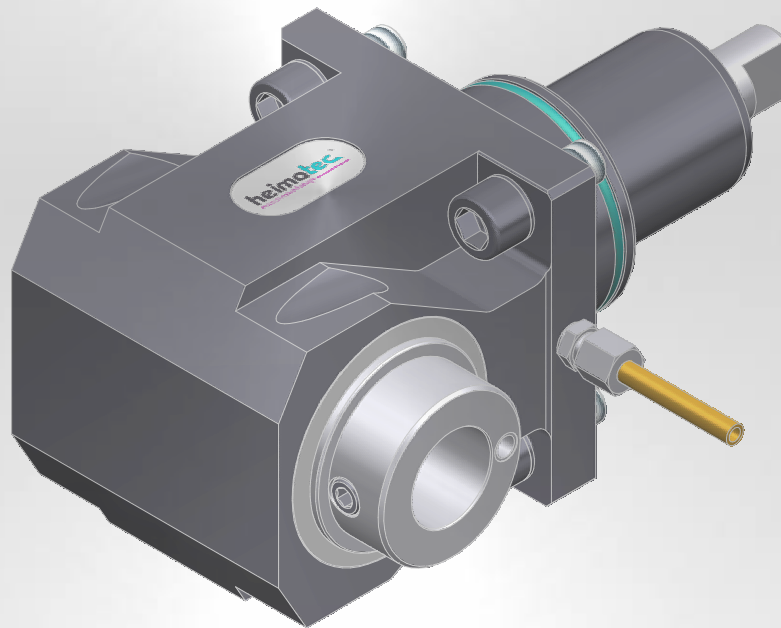

HYUNDAI WIA

L 2100 Y

L 2100 SY



Hinweis zu den AGBs:

Diese finden Sie in unserem Internetauftritt unter

www.heimatec.de

Home/Impressum/AGB

Terms and conditions:

You will find them on our website

www.heimatec.com

Home/Imprint/Terms and Conditions

Das Katalog-Werk einschließlich aller seiner Teile ist urheberrechtlich geschützt. Jede Verwertung außerhalb der engen Grenzen des Urheberrechtsgesetzes ist ohne Zustimmung der Rechteeinhaber unzulässig und strafbar. Das gilt insbesondere für Vervielfältigungen, Übersetzungen, Mikroverfilmungen und die Einspeicherung und Verarbeitung in elektronischen Systemen.

heimatec® GmbH behält sich Änderungen technischer Art jederzeit ohne Vorankündigung vor. Dies gilt insbesondere bei Anpassungen an neue oder geänderte internationale Normen oder bei Weiterentwicklungen unserer Produkte oder Herstellungsprozesse.

This catalogue, including all its parts, is protected by copyright. Each use outside the restricted limitations of the Copyright Act is inadmissible and liable to prosecution without the consent of heimatec. This is particularly valid for duplication, translation, microfilming and feeding and processing in electronic systems.

heimatec® GmbH reserves the right of technical changes everytime without advance notice, which is particularly valid for adaptations to new or changed international standards, or to developments of our products or manufacturing processes.

angetriebene Werkzeuge
driven tools



Axial-Bohr- und Fräskopf
axial drilling and milling head

$n_{max} = 6000 \text{ min}^{-1}$

8 010 66 079	ER 32 AX u-tec	EK	1:1
8 010 66 081	ER 32 AX u-tec	IK 25 bar	1:1
8 010 66 046	ER 32 AX u-tec	IK 70 bar	1:1
8 010 67 025	easy-quick HT 5	EK	1:1
8 010 67 026	easy-quick HT 5	IK 25 bar	1:1
8 010 67 060	easy-quick HT 5	IK 70 bar	1:1



Axial-Bohr- und Fräskopf
axial drilling and milling head

$n_{max} = 24000 \text{ min}^{-1}$

8 013 64 008	ER 16 AX u-tec	EK	1:4
8 013 64 009	ER 16 AX u-tec	IK 70 bar	1:4



Axial-Bohr- und Fräskopf
axial drilling and milling head

$n_{max} = 6000 \text{ min}^{-1}$

8 011 65 014	Kombidorn/universal arbor 22	EK	1:1
8 011 65 011	Kombidorn/universal arbor 1"	EK	1:1



Axial-Bohr- und Fräskopf
axial drilling and milling head

Achsversatz / offset $A=50$

8 019 65 021	ER 25 AX u-tec	EK	1:1
8 019 65 022	ER 25 AX u-tec	IK 140 bar	1:1
$n_{max} = 6000 \text{ min}^{-1}$			
8 019 65 004	ER 25 AX u-tec	EK	1:2
8 019 65 027	ER 25 AX u-tec	IK 140 bar	1:2
$n_{max} = 12000 \text{ min}^{-1}$			
8 019 65 023	ER 25 AX u-tec	EK	2:1
8 019 65 024	ER 25 AX u-tec	IK 140 bar	2:1
$n_{max} = 3000 \text{ min}^{-1}$			
8 019 65 025	ER 25 AX u-tec	EK	1:3
8 019 65 026	ER 25 AX u-tec	IK 140 bar	1:3
$n_{max} = 15000 \text{ min}^{-1}$			

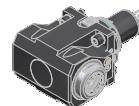
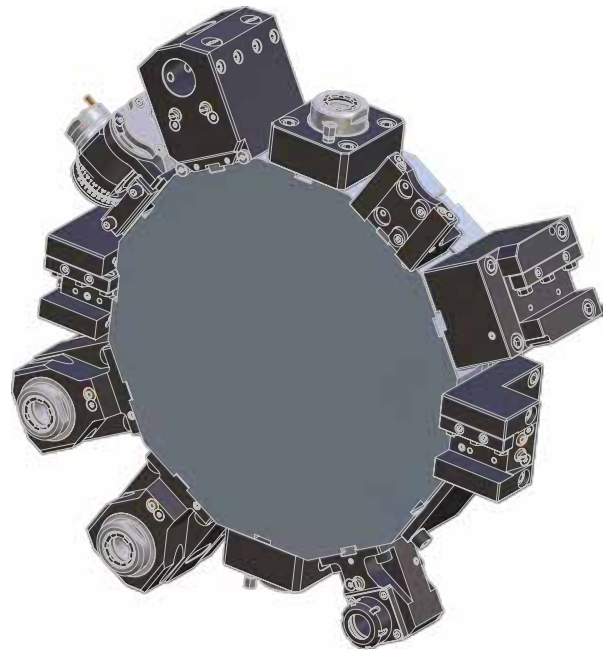

Winkel-Bohr- und Fräskopf
radial drilling and milling head

Mittenmaß / center distance $H=72$
 $n_{max} = 6000 \text{ min}^{-1}$

8 030 66 097	ER 32 AX u-tec	EK	1:1
8 030 66 098	ER 32 AX u-tec	IK 140 bar	1:1
8 030 67 025	easy-quick HT 5	EK	1:1
8 030 67 075	easy-quick HT 5	IK 140 bar	1:1

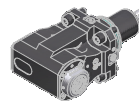

Axial-Bohr- und Fräskopf
axial drilling and milling head

Mittenmaß / center distance $H=95$

8 030 65 055	ER 25 AX u-tec	EK	1:2
8 030 65 063	ER 25 AX u-tec	IK 140 bar	1:2
$n_{max} = 12000 \text{ min}^{-1}$			
8 030 65 064	ER 25 AX u-tec	EK	1:3
8 030 65 065	ER 25 AX u-tec	IK 140 bar	1:3
$n_{max} = 18000 \text{ min}^{-1}$			

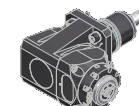

Winkel-Bohr- und Fräskopf
radial drilling and milling head

Mittenmaß / center distance $H=72$
 $n_{max} = 24000 \text{ min}^{-1}$

8 030 64 021	ER 16 AX u-tec	EK	1:4
8 030 64 023	ER 16 AX u-tec	IK 140 bar	1:4

► Weitere Ausführungen auf Anfrage
further versions on request

► Zubehör **ZB...***
accessories **ZB...***

► easy-quick



► u-tec



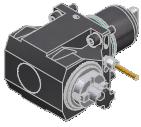

Winkel-Bohr- und Fräskopf radial drilling and milling head

Mittenmaß / center distance $H=72$
 $n_{max} = 6000 \text{ min}^{-1}$

8 031 65 015	Kombidorn/universal arbor 22	EK	1:1
8 031 65 010	Kombidorn/universal arbor 1"	EK	1:1

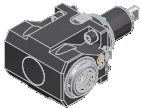

Winkel-Bohr- und Fräskopf radial drilling and milling head

Mittenmaß / center distance $H=72$
doppelspindlig / double spindle
 $n_{max} = 6000 \text{ min}^{-1}$

8 039 66 025	ER 32 AX u-tec	EK	1:1
8 039 67 009	easy-quick HT 5	EK	1:1



Schwenkkopf universal head

Mittenmaß / center distance $H=69$
Achsversatz / offset $A=60$

8 043 65 000	ER 25 AX u-tec	EK	1:1
8 043 65 004	ER 25 AX u-tec	IK 140 bar	1:1
$n_{max} = 6000 \text{ min}^{-1}$			
8 043 64 008	ER 16 AX u-tec	EK	1:2
8 043 64 009	ER 16 AX u-tec	IK 140 bar	1:2
$n_{max} = 12000 \text{ min}^{-1}$			

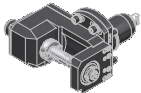

Winkel-Scheibenfräserkopf radial disk mill head

$\pm 10^\circ$ drehbar
 $\pm 10^\circ$ turnable

Mittenmaß / center distance $H=87,5$
auf 0° absteckbar / 0° can be pinned
kein Kühlmittel / no coolant
 $n_{max} = 3000 \text{ min}^{-1}$

8 037 64 023	$\varnothing 16$	2:1
8 037 65 008	$\varnothing 22$	2:1
8 037 64 003	$\varnothing 3/4"$	2:1
8 037 65 019	$\varnothing 1"$	2:1

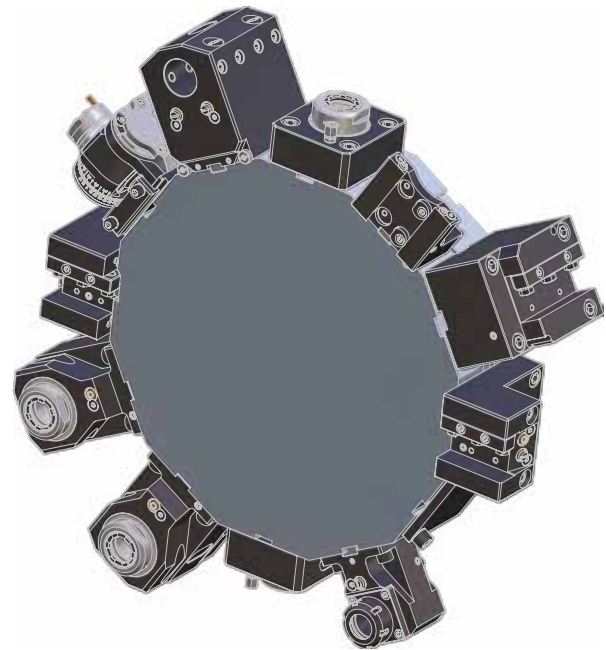

► Weitere Ausführungen auf Anfrage
further versions on request

► Zubehör ZB...*
accessories ZB...*

► easy-quick

► u-tec

feste Werkzeuge static tool holders

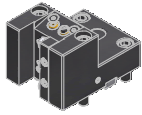

Kombi-Drehstahlhalter
universal turning holder

8 224 15 006	Vierkant/square 25	EK
8 224 15 016	Vierkant/square 1"	EK

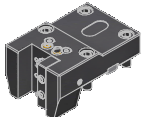

Kombi-Drehstahlhalter
universal turning holder

8 224 15 005	Vierkant/square 25	EK
8 224 15 015	Vierkant/square 1"	EK

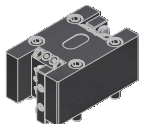

Kombi-Doppel-Drehstahlhalter
combi double turning holder

8 251 15 003	Vierkant/square 25	EK
8 251 15 008	Vierkant/square 1"	EK

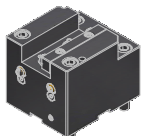

Kombi-Plandrehhalter
combi facing holder

8 244 15 005	Vierkant/square 25	EK
8 244 15 006	Vierkant/square 1"	EK



Bohrstangenhalter
boring bar holder

Mittenmaß / center distance H=72

8 240 18 028	ø32	IK/EK
8 240 19 032	ø40	IK/EK
8 240 19 044	ø1,5"	IK/EK
8 240 19 048	ø2"	IK/EK

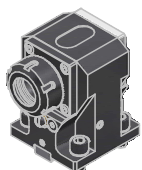

Spannzangenhalter
collet chuck holder

Mittenmaß / center distance H=72

8 240 16 021	ER 32	IK/EK
--------------	-------	-------

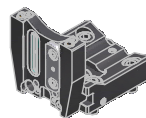
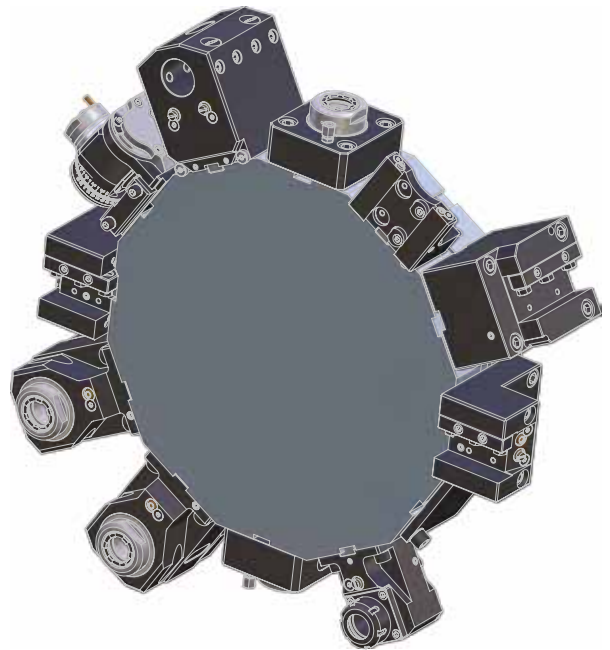

Abstechhalter
cut-off holder

höhenverstellbar / height adjustable

8 320 13 005	SH 32	IK 70 bar
--------------	-------	-----------

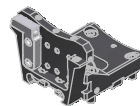

Abstechhalter
cut-off holder

höhenverstellbar / height adjustable

8 320 19 000	HORN System 845	IK 70 bar
--------------	-----------------	-----------

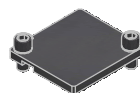

Abdeckblech
cover plate

8 200 03 005	
--------------	--

► Weitere Ausführungen auf Anfrage
further versions on request

► Zubehör ZB...*
accessories ZB...*

► easy-quick

► u-tec

► **easy-quick HT Schnellwechselsystem**
easy-quick HT fast change system

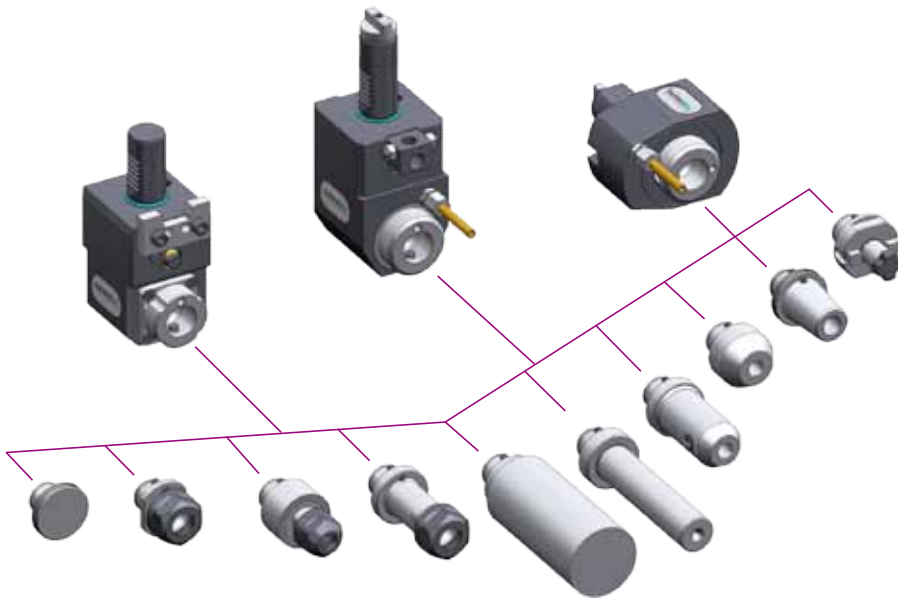

DAS Schnellwechselsystem von heimatec
für angetriebene und feste Werkzeuge

*THE fast change system of heimatec
for driven and static tools*

www.heimatec.de
Produkte / easy-quick

www.heimatec.com
products / easy-quick

► Ausführungen siehe Katalog
versions see catalogue



► **u-tec[®] UT Wechselsystem**
u-tec[®] UT change system

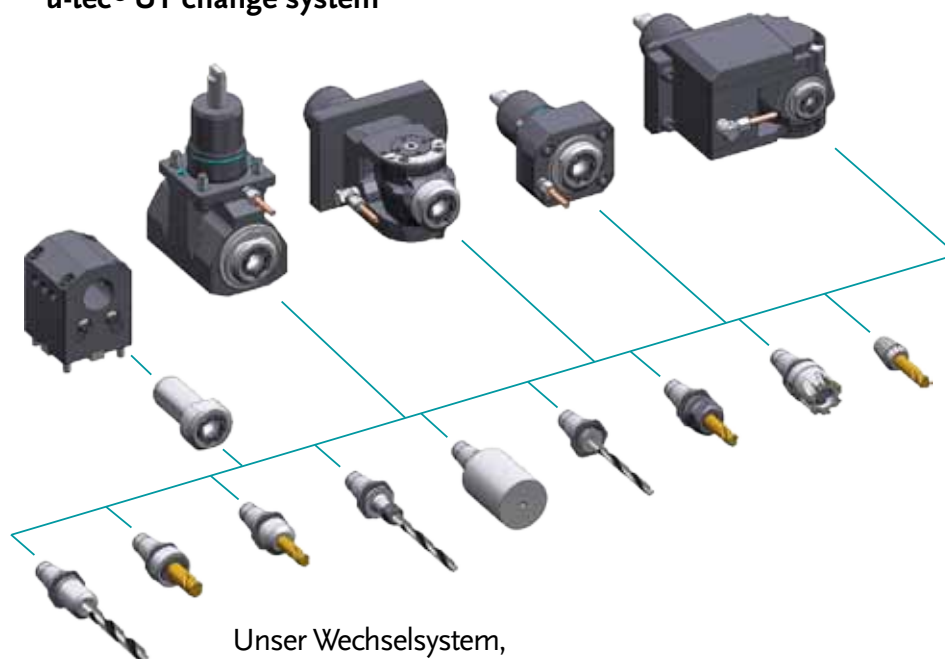

Unser Wechselsystem,
das ALLES möglich macht

Our change system,
that makes EVERYTHING possible

www.heimatec.de
Produkte / u-tec

www.heimatec.com
products / u-tec

► Ausführungen siehe Katalog
versions see catalogue



heimatec®

- heimatec®-Niederlassungen
heimatec® overseas branches
- unsere weltweiten Vertretungen
global representations of heimatec®

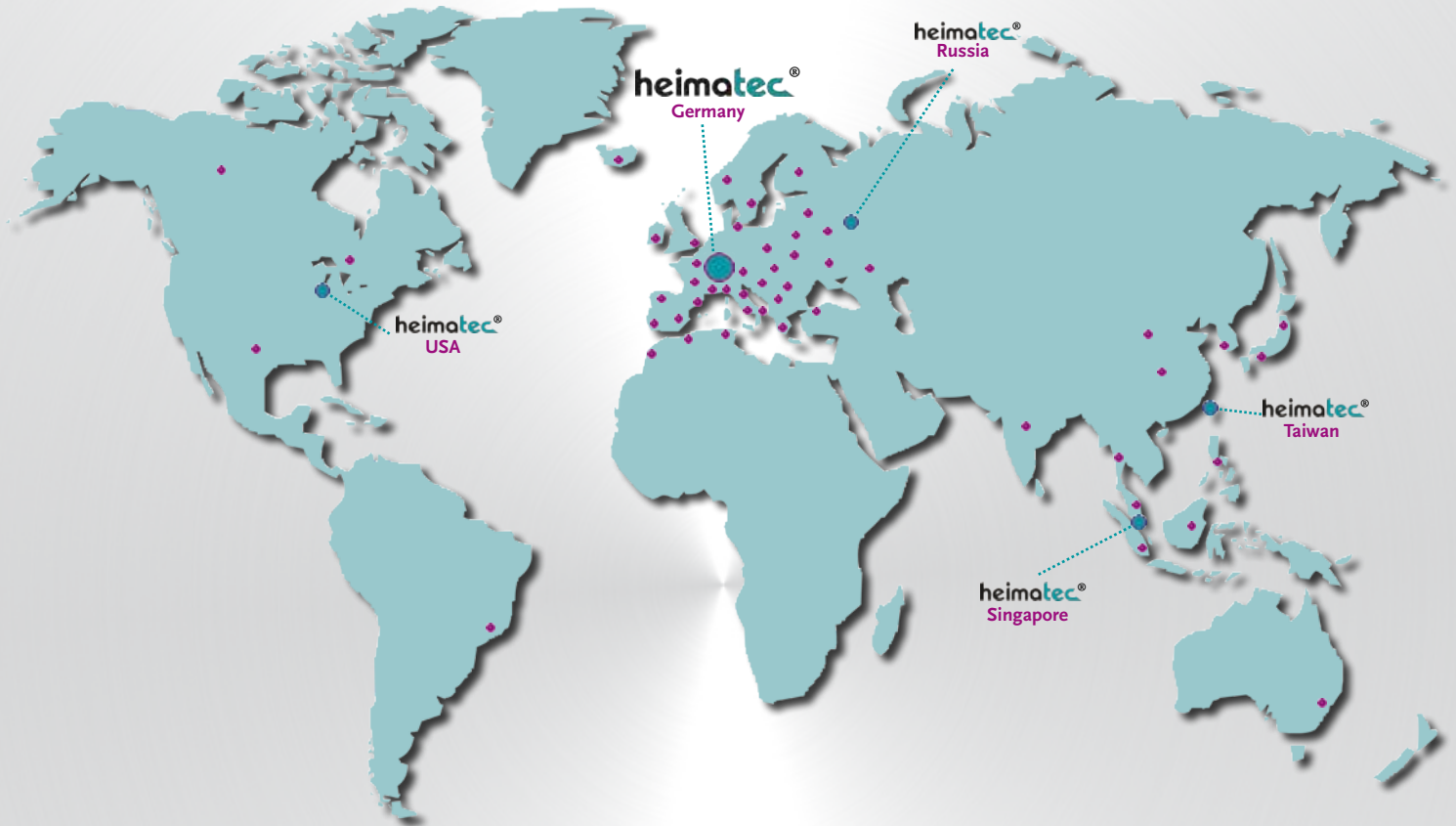

Hauptsitz/headquarters

heimatec® GmbH
Präzisionswerkzeuge
Carl-Benz-Straße 4
D- 77871 Renchen
Postfach 11 36
D- 77867 Renchen
Tel.: +49 (78 43) 94 66 0
Fax: +49 (78 43) 94 66 66
heimatec.de
info@heimatec.de

heimatec® Inc.
USA
usa.heimatec.com
USA@heimatec.com

heimatec®-Ost, JSC
Russia
ru.heimatec.com
Russia@heimatec.com

heimatec® Ltd.
Taiwan
tw.heimatec.com
Taiwan@heimatec.com

heimatec®
Singapore
sg.heimatec.com
Singapore@heimatec.com

